



FREE STANDING TIPPER

LUG LIFT or COMB LIFT

KADANT PAAL LIMITED IS THE UK'S LEADING MANUFACTURER AND
SUPPLIER OF WASTE COMPACTORS AND BALING EQUIPMENT.

DICOM

SAFETY :

All Dicom's products are designed and manufactured with operator safety our highest priority.

Each compactor comes fully compliant to all current Safety Standards and CE Marked.

During installation full safety and certified operator training is provided by our highly experienced installation engineers.

Equipment is supplied with the following standard safety features :

- Emergency Stop
- 24 Volt controls
- Dual safety switches
- Dual channel safety relays
- Operator manuals supplied

Technical Data and Measurements

Lifting Capacity	500 kgs	Control Voltage	24 Volt
Motor	4 Kw	Hydraulic Pressure	2000 Psi

Electrical Supply Requirements	16A 3-phase with neutral and earth. Protection via Type "D" circuit breaker or Motor rated fuses
--------------------------------	---

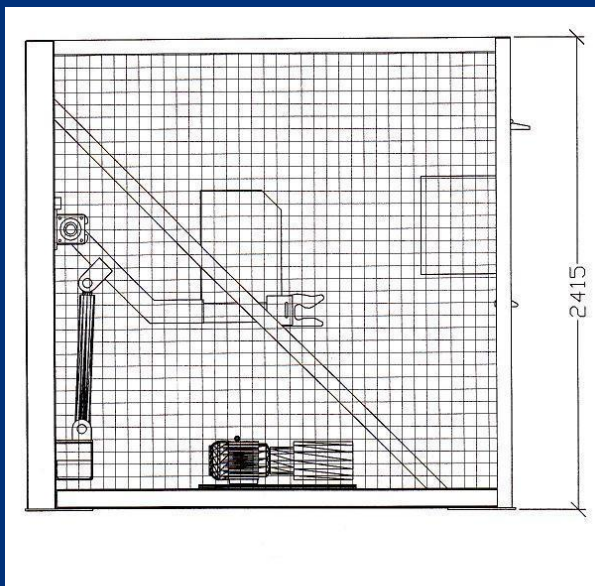
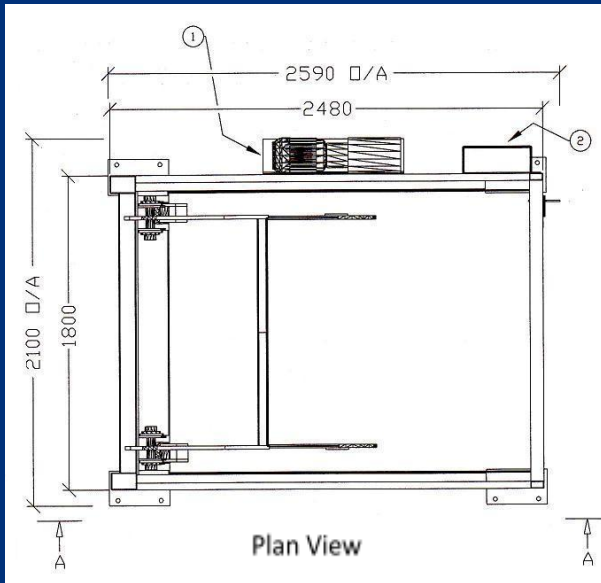

Power Pack
Control Panel

